

# UPE

## UPE Universal Range Wide Tolerance Couplings, Flange Adaptors and End Caps

### Benefits

- Available in a range of stepped and equal couplings and flange adaptors from 40mm - 300mm (1½" - 32")
- A wide tolerance of up to 25mm means extreme versatility of use
- Wide tolerances allow for reduced stock holdings
- Quick and efficient installation without disassembly or any loose components
- Suits all common rigid pipe materials
- Prolonged life of fitting due to the high quality corrosion protective coating used

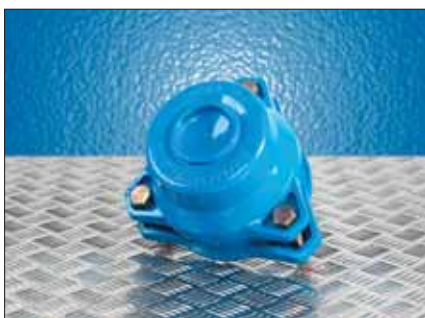
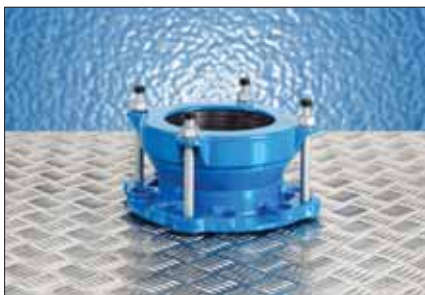
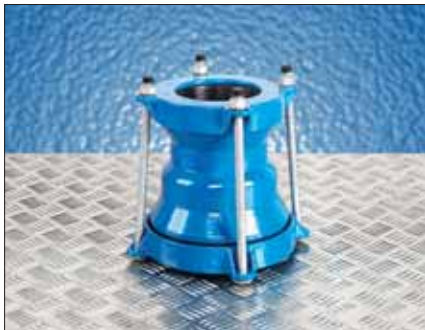

The UPE Universal range of wide tolerance couplings, stepped couplings, flange adaptors and end caps can be used on almost any plain-ended rigid pipe material from 40mm to 300mm pipe nominals. This flexibility combined with each fittings ability to accommodate a wide variety of pipe sizes makes the UPE Universal fitting a versatile and economical product to use.



### Technical data

Pressures	Working	Test
Water:	16 bar	24 bar
Gas:	7 bar	11 bar

Higher pressure options are available on request. For further details please contact our customer service department at the telephone number shown below.

Temperature: Up to 50°C

Higher temperatures may affect the installed life of the product. For further information relating to operating temperatures please contact our customer service department at the telephone number shown below.

Flange type :

PN10/16 BS4504

ANSI, BS10, AS2129 & AS4087 (available on request)

Max angular deflection:

Flange Adaptors and End Caps: +/- 3°

Couplings: +/- 6°

Material:

Body: Ductile Iron or Steel

Gland Rings: Ductile Iron or Steel

Coating:

Fusion bonded epoxy to WIS 4-52-01

Blue for EPDM service, black for Nitrile service.  
(Alternative coatings are available on request)

Fasteners:

Bolts & Nuts: Mild Steel to BS 4399  
Coated to WIS 4-52-03

Washers: Stainless Steel

(Alternative fastener coatings are available on request)

Sealing Gaskets:

Water EPDM (EN 681)

Gas Nitrile (EN 682)

### General application

Tolerances between the minimum and maximum sizes of each fitting vary between 13mm and 25mm. This wide range makes the UPE Universal product exceedingly versatile and particularly suitable for connecting pipes of different rigid materials such as Asbestos cement, PVC or Cast Iron.

The bolts are fully coated to WIS 4-52-03. PVC end caps are fitted on the bolt threads for additional protection during transit. Other bolt materials and specifications are available on special request.

All materials used with the UPE Universal fitting that come into contact with potable water are WRAS listed.

UPE Universal couplings, flange adaptors and end caps are not fully end load restrained, please ensure adequate restraint is provided. These fittings are not suitable for use on PE pipe.

### Safety

As with all industrial products it is important to take adequate safety precautions such as the use of adequate protective clothing like gloves, overalls, eye protection and safety footwear during use, maintenance and installation.

### Technical help

For further technical data, product specifications and general information please contact our Customer Service or Technical Departments at the telephone number shown below.

# Mains Connections - Universal

2

## The UPE Universal Range

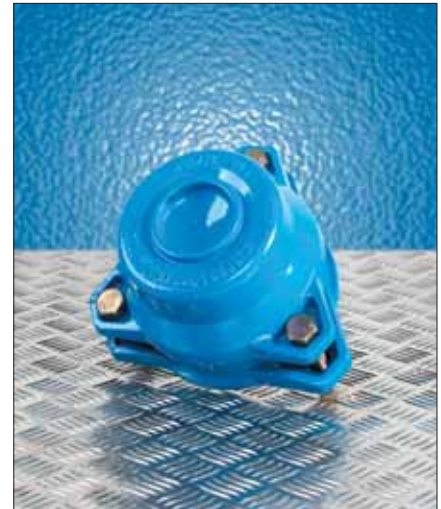
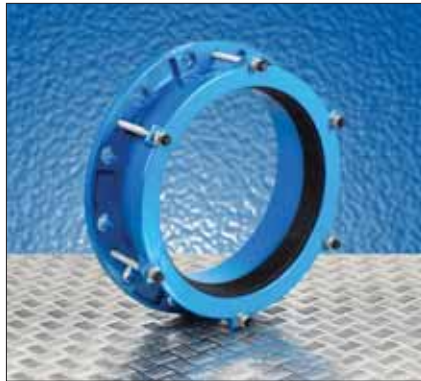
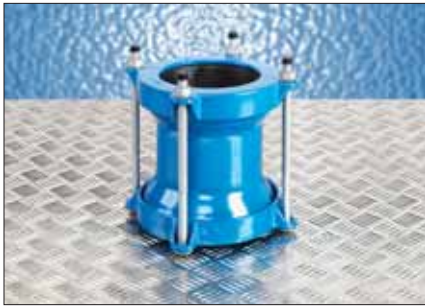

**UniDap**  
Universal Flange Adaptors

**UniCup**  
Universal Couplings  
and Stepped Couplings

**UniCap**  
Universal End Caps



### Limitations For Use

The UPE Universal range is not fully end load resistant, please ensure adequate restraint is provided. These fittings are not suitable for use on PE pipe.

## How the Universal Fitting Works



To install the fitting loosen the bolts and slide the fitting over the end of the pipe.

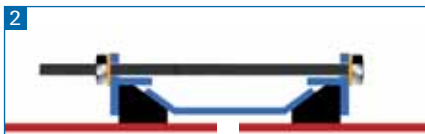

Once the fitting has been correctly positioned, tighten the bolts evenly in a diametrically opposing sequence to a torque of 61 - 68 Nm (45 - 50 lbf.ft). As the bolts are tightened, the gland ring(s) are drawn in, compressing the rubber seal(s) around the pipe, creating a leak free connection.



## Corrosion Protection

The WIS 4-52-01 coating offers excellent impact and abrasion resistance. This durable coating removes the need for further on site protection and gives the fitting an excellent installed life span.

The captivated bolts are fully coated and are approved to WIS 4-52-03.

PVC end caps are fitted on the bolt threads for additional protection during transit. Other bolt materials are available on special request.



## Technical Help

For further technical data, product specifications and general information please contact our Customer Service or Technical Departments on the telephone number shown on the back of this data sheet.



## Installation Instructions

All UPE fittings are supplied ready assembled and pre lubricated allowing for efficient installation on site.

### Couplings - Straight and Stepped

#### Preparation

Select the correct type and size of fitting for the situation and ensure that the pipe that is being connected to is clean, round and free from deep scratches, scores or general imperfections that may prevent an effective seal being created.

Also ensure that the relative angle of the two pipes conforms to suggested maximum angular deflection for couplings of +/- 6°.

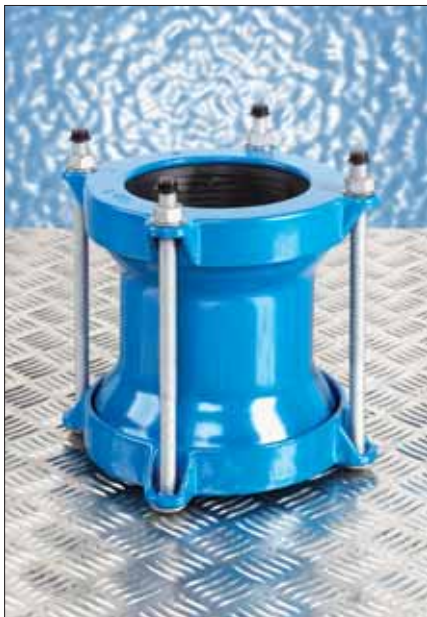

#### Assembly Procedure

- 1a Slide the fitting over one of the pipes to be connected
- 1b For stepped couplings the fitting should be slid over the smaller diameter pipe
- 2 Line up the other pipe end (ensuring that a setting gap of approximately 18mm is maintained).
- 3 Mark the pipe to ensure accurate location of the fitting over the setting gap.
- 4 Locate the fitting using the marks and, to ensure an even fit, tighten the fasteners in a diametrically opposed sequence to a torque of: M12: 61- 68 Nm (45 - 50lb.ft)

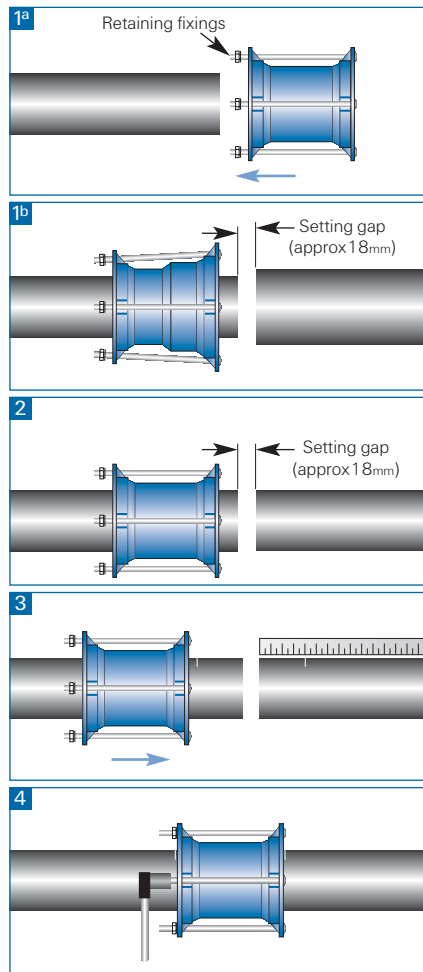

### Flange Adaptors - Straight and Stepped

#### Preparation

Select the correct type and size of fitting for the situation and ensure that the pipe to be connected to is clean, round, free from deep scratches, scores or general imperfections that may prevent an effective seal. Also ensure that the relative angle of the pipe to the fitting conforms to suggested maximum angular deflection for flange adaptors and end caps of +/- 3°.

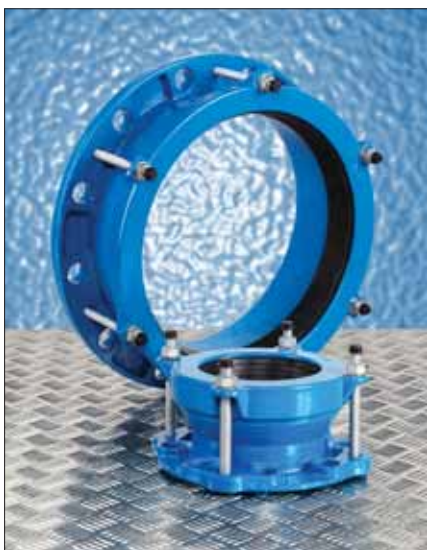

#### Assembly Procedure

- A Slide the fitting over the plain ended pipe to be connected
- B Line up the pipe end with the flanged pipe and insert a suitable gasket between the mating flanges (ensure that a setting gap of approximately 18mm is maintained)
- C Bolt the flanges together ensuring the gasket remains in place
- D For both flange adaptors and end caps tighten the flange adaptor retaining fasteners in a diametrically opposed sequence to a torque of: M12: 61- 68 Nm (45 - 50lb.ft)

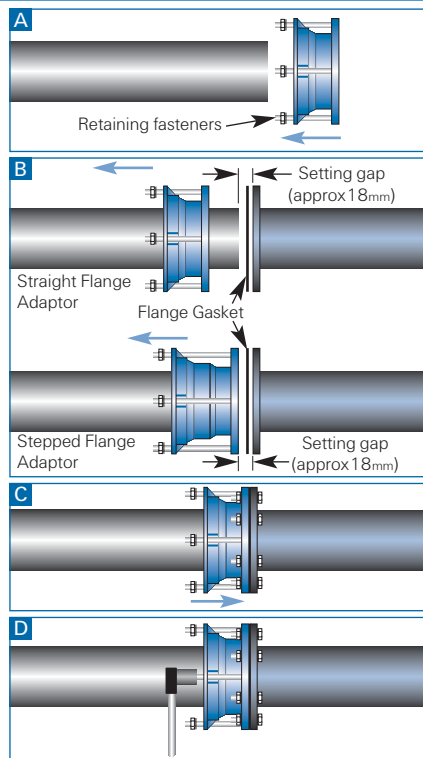

#### NB

UPE Universal couplings and flange adaptors are not fully end load restrained, please ensure adequate restraint is provided. These fittings are not suitable for use on PE pipe.

## Range, Dimensions and Details - Couplings (Straight)

Size Nominal Bore	Tolerance Range (mm)
40mm / 1 1/2"	44 - 60
50mm / 2"	60 - 72
65mm / 2 1/2"	75 - 84
80mm / 3"	84 - 106
100mm / 4"	108 - 131
125mm / 5"	131 - 154
150mm / 6"	159 - 184
175mm / 7"	183 - 208
200mm / 8"	219 - 234
200mm / 8"	234 - 255
225mm / 9"	242 - 262
250mm / 10"	265 - 280
250mm / 10"	273 - 290
250mm / 10"	284 - 297
300mm / 12"	315 - 331
300mm / 12"	324 - 338
300mm / 12"	335 - 348

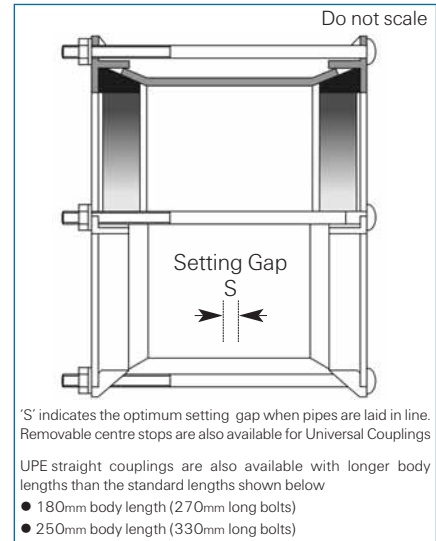

## Range, Dimensions and Details - Couplings (Stepped)

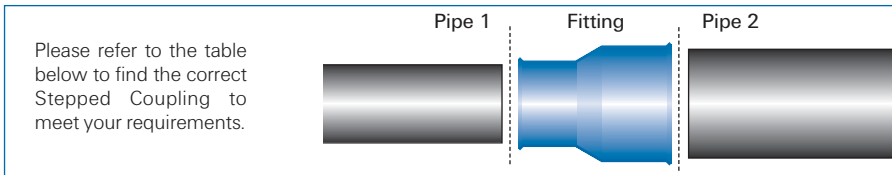

Pipe 1 Nominal Bore	Pipe 1 Tol. Range (mm)	Pipe 2 Nominal Bore	Pipe 2 Tol. Range (mm)
40mm / 1 1/2"	44 - 60	50mm / 2"	60 - 72
40mm / 1 1/2"	44 - 60	65mm / 2 1/2"	75 - 84
50mm / 2"	60 - 72	65mm / 2 1/2"	75 - 84
50mm / 2"	60 - 72	80mm / 3"	84 - 106
65mm / 2 1/2"	75 - 84	80mm / 3"	84 - 106
65mm / 2 1/2"	75 - 84	80mm / 3"	84 - 106
80mm / 3"	84 - 106	100mm / 4"	108 - 131
100mm / 4"	108 - 131	125mm / 5"	131 - 154
125mm / 5"	125 - 140	150mm / 6"	159 - 179
125mm / 5"	125 - 140	150mm / 6"	176 - 188
125mm / 5"	125 - 140	150mm / 6"	159 - 184
125mm / 5"	131 - 154	150mm / 6"	159 - 184
125mm / 5"	139 - 154	150mm / 6"	176 - 188
150mm / 6"	159 - 179	150mm / 6"	176 - 188
150mm / 6"	159 - 184	175mm / 7"	183 - 208
150mm / 6"	176 - 188	175mm / 7"	184 - 198
150mm / 6"	176 - 188	175mm / 7"	192 - 208
175mm / 7"	184 - 198	175mm / 7"	192 - 208
175mm / 7"	184 - 208	200mm / 8"	219 - 234
175mm / 7"	184 - 198	200mm / 8"	234 - 255
175mm / 7"	184 - 208	200mm / 8"	234 - 255
200mm / 8"	219 - 234	200mm / 8"	234 - 255
200mm / 8"	219 - 234	225mm / 9"	242 - 262
200mm / 8"	234 - 235	225mm / 9"	242 - 262
225mm / 9"	242 - 262	250mm / 10"	265 - 280
225mm / 9"	242 - 262	250mm / 10"	273 - 290
225mm / 9"	242 - 262	250mm / 10"	284 - 279
250mm / 10"	265 - 280	250mm / 10"	273 - 290
250mm / 10"	265 - 280	250mm / 10"	284 - 297
250mm / 10"	273 - 290	250mm / 10"	284 - 297
300mm / 12"	315 - 331	300mm / 12"	324 - 338
300mm / 12"	315 - 331	300mm / 12"	335 - 348
300mm / 12"	324 - 338	300mm / 12"	335 - 348

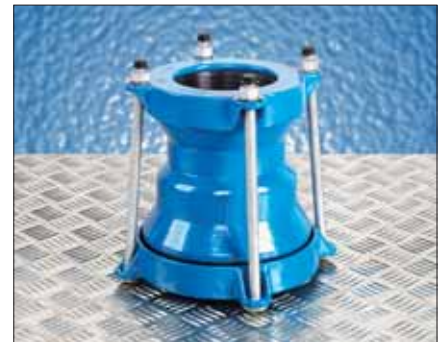

### Special Applications

For duties requiring fittings larger than DN300 or with higher tolerance ranges please refer the MultiDiameter range of wide tolerance fittings.

- Sizes available up to DN800
- Up to 43mm of working tolerance
- Fittings available ex stock

Details relating to the UPE range of MultiDiameter fittings can be found in the data sheet TUPE/200.

*Wide Tolerance Couplings and Flange Adaptors.*

Please contact the customer service team on the number shown on the back of this data sheet or alternatively visit the Tyco Waterworks web site on [www.tycowaterworks.com](http://www.tycowaterworks.com).



## Universal Flange Adaptors

'S' indicates the optimum setting gap when the pipe is laid with no angular deflection.

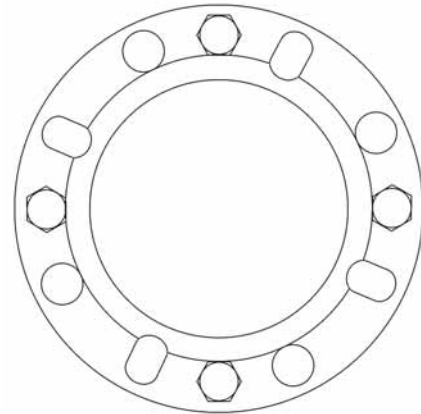
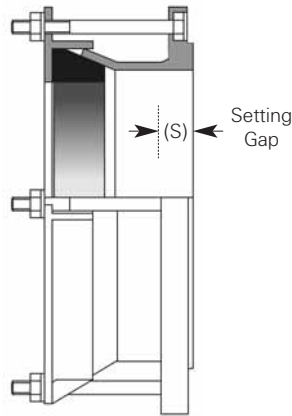

Do not scale

## Universal Flange Adaptor Dimensions and Details

Size Nominal Bore	Flange Size	Tolerance Range (mm)	Bolts		Flange Specification		
			Length (mm)	No.	EN1515-1 (2000)	BS10 (1962)	ASA
50mm / 2"	50mm/2"	60 - 72	100	2	PN10, PN16	A.D.E	125
50mm / 2"	80mm/3"	60 - 72	100	2	PN10, PN16	A.D.E	125
65mm/2 1/2"	80mm/3"	75 - 84	100	2	PN10, PN16	A.D.E	125
80mm / 3"	80mm/3"	84 - 106	100	4	PN10, PN16	A.D.E	125
80mm / 3"	80mm/3"-100mm/4"	84 - 106	100	4	PN10, PN16	A.D.E	125
100mm / 4"	100mm/4"	108 - 131	100	4	PN10, PN16	A.D.E	125
125mm / 5"	125mm/5"	125 - 140	100	4	PN10, PN16	A.D.E	125
125mm / 5"	125mm/5"	139 - 153	100	4	PN10, PN16	A.D.E	125
125mm / 5"	150mm/6"	125 - 140	100	4	PN10, PN16	A.D.E	125
150mm / 6"	150mm/6"	159 - 184	140	4	PN10, PN16	A.D.E	125
175mm / 7"	200mm/8"	184 - 198	140	4	PN10, PN16	D.E	125
200mm / 8"	200mm/8"	219 - 234	140	6	PN10, PN16	E	125
200mm / 8"	200mm/8"	234 - 255	140	6	PN16	D.E	125
225mm / 9"	250mm/10"	242 - 262	140	6	PN10, PN16	D.E	125
250mm / 10"	250mm/10"	265 - 280	140	6	PN10, PN16	Dimensions and technical data for alternative flange drillings is available on request.	
250mm / 10"	250mm/10"	273 - 290	140	6	PN10, PN16		
250mm / 10"	250mm/10"	242 - 262	140	6	PN10, PN16		
300mm / 12"	300mm/12"	284 - 297	140	6	PN10, PN16		
300mm / 12"	300mm/12"	315 - 331	140	6	PN10, PN16		
300mm / 12"	300mm/12"	335 - 348	140	6	PN10, PN16		
300mm / 12"	300mm/12"						

All UPE UniDap Universal Flange Adaptors have grooved raised flange faces for optimum sealing capability.



## Fasteners and Flange Gasket Sets

UPE offer complete flange gasket sets consisting of a gasket and the appropriate number of bolt sets for the size of flange. These flange gasket sets are supplied bagged and clearly labelled enabling the correct gasket with the correct number of bolts, nuts and washers to be selected every time a connection is to be made. Bolts are approved to WIS 4-52-03.

For further information on the UPE range of Fasteners and Flange Gasket Sets please refer to Data Sheet 2000.1 'Fasteners and Flange Gasket Sets' or contact the UPE Customer Service Team at the number shown on the back of this data sheet.



# Mains Connections - Universal

6

## Universal End Caps

The UPE Unicap can be used for mains abandonment, mains replacement schemes or any other applications that require a pipe to be capped.

### Universal End Cap Dimensions and Details

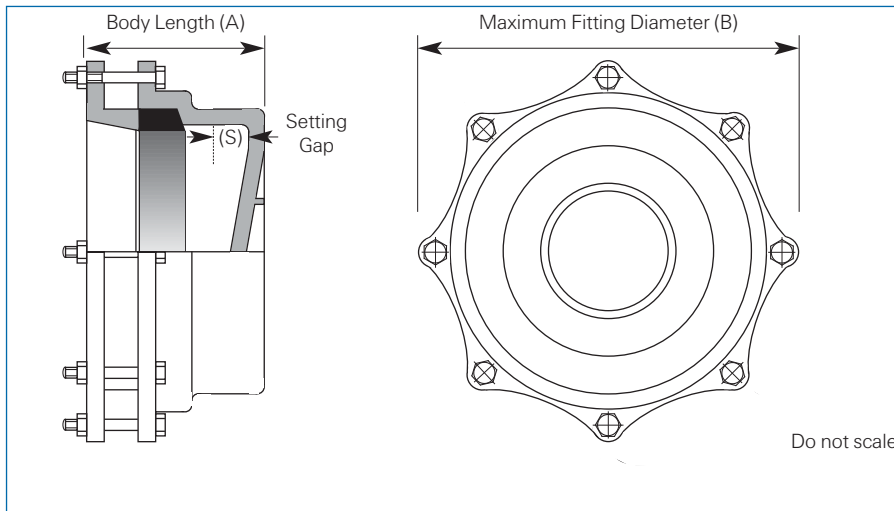

### Universal End Caps

Size Nominal Bore	Pipe Tolerance (mm)	A (mm)	B (mm)	S (mm)	Bolts Length	Bolts No.	Weight (kg)
80mm / 3"	88.9 - 98.0	112	210	18	100	3	7.0
100mm / 4"	114.3 - 121.9	112	240	18	100	3	5.2
125mm / 5"	145.0 - 150.0	132	285	18	100	3	8.4
150mm / 6"	168.3 - 177.3	112	295	18	100	3	6.9
175mm / 7"	200.0 - 204.7	152	345	18	100	3	16.0
200mm / 8"	219.1 - 232.2	152	355	18	130	5	10.5
225mm / 9"	255.0 - 259.1	152	390	18	130	8	22.0
250mm / 10"	273.0 - 286.0	152	416	18	130	8	23.7
300mm / 12"	323.9 - 333.8	152	466	18	130	10	33.1

### Notes

For information relating to fittings over 300mm please contact our Customer Service or Technical Departments at the telephone number shown on the back of this data sheet.

### Applications

UPE UniCaps will connect onto the following pipe materials for water and gas supplies:

- Ductile Iron
- Cast Iron
- Steel
- GRP
- uPVC
- Asbestos Cement
- ABS
- MOPVC

### Applications

The UPE UniCap is designed for all potable water and waste water applications up to a working pressure of 16 bar. For gas distribution applications product is approved for pressures up to 7 bar (100 lb/sq inch).

The fitting can be drilled and tapped to allow for a variety of additional functions to be carried out such as:

- Bleeding of air from water systems
- Draining systems
- Reduction and adaptation to PE pipe via a threaded adaptor
- Insertion of pressure gauges
- Fitment of pumps to fill or test the network
- Gas mains abandonment

### NB

UPE UniCap end caps are not fully end load restrained, please ensure adequate restraint is provided. These fittings are not suitable for use on PE pipe.

### Technical help

For further, more detailed technical data, please contact our Customer Service or Technical Departments at the telephone number shown on the back of this data sheet.

## Mains Connections for Rigid Pipes - 40mm - 300mm

### UPE Universal Fittings



## Standard Outside Pipe Diameter Guide Chart

Nominal Bore	Imperial Cast Iron and A C (turned end) BS 1211 (up to and including 27" NB) BS78, BS486			Steel						UPVC		ABS	Ductile Iron	GRP	Metric AC (turned end) BS486		
	Class AB Only	Class CD Only	Non Standard	ISO/4200			BS1387	BS3600 & BS3601 (pipe ends to BS534)	API 5L & BS1600 (up to and including 36" NB)	BS3505	BS3506	BS5391	BS4772 DIN28601 DIN28602 DIN28603	BS5480	Class 15	Class 20	Class 25
				Ser 1	Ser 2	Series 3											
15mm 0.5"				21.3			21.3	21.4	21.4	21.4	21.4	21.4					
20mm 0.75"				26.9	25.0	25.4	26.9	26.8	26.7	26.8	26.8	26.8					
25mm 1"				33.7	32.0	30.0	33.7	33.6	33.4	33.6	33.6	33.6					
32mm 1.25"				42.4	40.0	44.5	42.4	42.3	42.2	42.3	42.3	42.3					
40mm 1.5"	55.9	55.9 2.20	57.0 2.20	48.3 2.25	57.0	54.0	48.3	48.3	48.3	48.3	48.3	48.3	56.0 DIN	28601			
50mm 2"	69.1 2.72	69.1 2.72		60.3	63.5		60.3	60.3	60.3	60.3	60.3	60.3	66.0 DIN 28605				69.0
65mm 2.5"	82.3 3.24	82.3 3.24	82.5 3.25	76.1	70.0	73.0	76.1	76.1	76.1	75.2	75.2		82.0 DIN 28605				
80mm 3"	95.5 3.76	95.5 3.76		88.9		82.5	88.9	88.9	88.9	88.9	88.9	88.9	98.0				96.0
90mm 3.5"				101.6	101.6			101.6	101.6								
100mm 4"	121.9 4.80	121.9 4.80		114.3	127.0	108.0	114.3	114.3	114.3	114.3	114.3	114.3	118.0				122.0
125mm 5"	149.4 5.90	149.4 5.90		139.7	133.0	141.3	139.7	139.7	141.3	140.2	140.2		144.0 DIN 28601/3				
150mm 6"	177.3 6.98	177.3 6.98		168.3		159.0	165.1	168.3	168.3	168.3	168.3	168.3	170.0		177.0		177.0
175mm 7"	204.7 8.06	204.7 8.06				193.7		193.7				193.7					
200mm 8"	232.2 9.14	232.2 9.14		219.1				219.1	219.1	219.1	219.1	219.1	222.0	222.0	232.0	232.0	240.0
225mm 9"	259.1 10.20	259.1 10.20				244.5		244.5				244.5			259.0	259.0	268.0
250mm 10"	286.0 11.26	286.0 11.26		273.0				273.0	273.1	273.0	273.0		274.0	272.0	286.0	286.0	295.0
300mm 12"	333.8 13.14	345.4 13.6		323.9				323.9	323.9	323.9	323.9		326.0	324.0	334.0	345.0	356.0
350mm 14"	386.6 15.22	399.3 15.72		355.6				355.6	355.6	355.6	355.6		378.0	376.0	392.0	405.0	419.0
375mm 15"	413.0 16.26	426.2 16.78															
400mm 16"	439.0 17.30	453.1 17.84		406.4				406.4	406.4	406.4	406.4		429.0	427.0	448.0	463.0	478.0
450mm 18"	492.3 19.38	506.9 19.96		457.0				457.0	457.0	457.0	457.0		480.0 (BS only)	478.0	498.0	515.0	532.0
500mm 20"	545.1 21.46	560.3 22.06		508.0				508.0	508.0	508.0	508.0		532.0	530.0	568.0	586.0	605.0
525mm 21"	571.5 22.50	587.2 23.12															
550mm 22"	597.9 23.54	613.7 24.16				559.0		559.0	559.0		559.0						
600mm 24"	650.2 25.60	667.0 26.26		610.0				610.0	610.0	610.0	610.0		635.0	633.0	654.0	672.0	691.0
650mm 26"	702.6 27.66	720.3 28.36				660.0		660.0	660.0								
675mm 27"	728.9 28.70	746.8 29.40															
700mm 28"	754.9 29.72	773.2 30.44		711.0				711.0	711.1				738.0	718.0	761.0	780.0	801.0
750mm 30"	807.2 31.78	826.0 32.52			762.0			762.0	762.0						808.0	830.0	852.0
800mm 32"	859.5 33.84	879.3 34.62		813.0				813.0	813.0				842.0	820.0	869.0	891.0	915.0

The above table represents a general guideline relating to some of the pipe types and sizes available. A wall chart is available showing the above information including sizes up to 2 meters. For a copy and for more detailed information please contact the UPE Customer Service Department on the number shown on the back of this data sheet.

### Universal Fittings 40-300mm



### Engineered Fittings 80-2,200mm

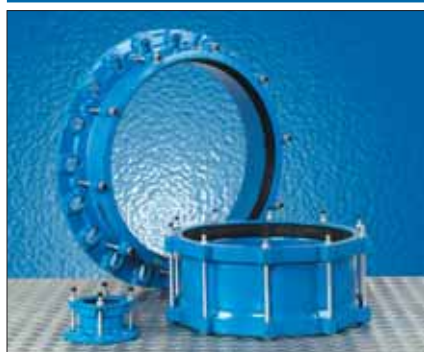

### MultiDiameter Fittings 32-800mm



Mains Connections for Rigid Pipes - 32mm - 2,200mm  
**UPE Range of Mains Fittings**

## Associated Products



*UPE Engineered fittings offer an effective method of connecting any rigid pipe material from 80mm to 2,200mm. Engineered Couplings connect pipe materials of the same or different outside diameter in any combination. Engineered Flange Adaptors connect pipes to a wide range of flange specifications. All Engineered fittings are made to the customers exact requirements and have a fitting tolerance of up to 11mm*

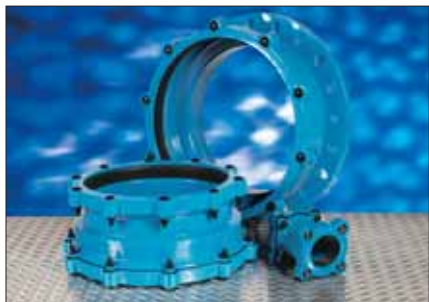

*The UPE MultiDiameter range of wide tolerance couplings and flange adaptors can be used for almost any plain-ended rigid pipe material from 32mm to 800mm pipe nominals.*

*This flexibility combined with each fittings ability to accommodate a wide variety of pipe sizes makes the UPE MultiDiameter fitting a versatile and economical product to use.*



*The Soft Sealing, Resilient Seated Gate Valve is manufactured to BS 5163 and EN1074 and is one of the lightest valves of its class on the market today. It has been specifically designed and developed with ease of use and length of installed service life in mind. Selection of robust, quality materials combined with engineering experience has enabled the development of a valve that solves many of the problems encountered when installing, operating and servicing gate valves.*

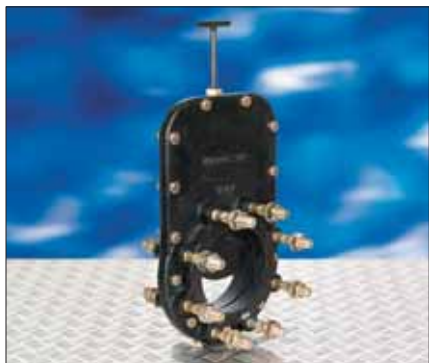

*The UPE Converter Slide Valve is an effective, full bore construction valve that will allow underpressure drilling operations to be performed on either water distribution systems under pressures of up to 10 bar or gas distribution systems under pressures of up to 7 bar.*

*Optimum space and weight savings have been made in the valve's design so providing a robust valve that is simple to install and use.*



*The UPE range of flange bolt sets is extensive and can be tailored to suit customers' exact needs.*

*UPE offer complete flange gasket sets consisting of a gasket and the appropriate number of fasteners for the size of flange. These flange gasket sets are supplied bagged and clearly labelled enabling the correct gasket with the correct size and number of bolts, nuts and washers to be selected every time a connection is to be made.*

## Tyco Waterworks

Edison Road  
Hams Hall Distribution Park  
Coleshill, Birmingham  
B46 1AB United Kingdom  
Telephone: +44 (0)1675 437 900  
Facsimile: +44 (0)1675 437 909  
e-mail: [wwinfo@tyco-valves.com](mailto:wwinfo@tyco-valves.com)  
web: [www.tycowaterworks.com](http://www.tycowaterworks.com)

**NEW**

# UPE

## UPE Universal Range

### Improved Wide Tolerance Couplings and Flange Adaptors

#### Benefits

- An increased tolerance of up to 28mm offers exceptional versatility
- Improved tolerances allow for even greater reductions in stock
- Unique, high efficiency seal design reduces installation time and effort
- Consistently secure joints are achieved due to the low torque requirement of 35 - 40Nm
- No disassembly of the fitting is required and there are no loose components
- Flange adaptor sleeve designed to ensure flange connecting bolts have full access without product disassembly
- Careful design and use of materials provides reduced weight for easy transportation and handling
- Increased angular deflection of +/- 5° for Flange Adaptors and +/- 10° for Couplings allows greater flexibility for the installer.
- Suits all common rigid pipe materials
- Prolonged life of fitting due to the high quality corrosion protective coating used

#### Testing - EN 14525

Amongst the EN14525 testing criteria is a need to complete a shear load cyclic test (fatigue test). This involves structural testing of each product size to 40 bar followed by all fittings being deflected 5° for each gasket for 24,000 cycles whilst under a cyclic pressure ranging from 5 bar to 18 bar.



## Mains Connections - Universal

This new generation of improved Universal fittings from UPE has enhanced features that offer significant customer benefits including reduced stocking, faster installation and conformance to the rigorous requirements of the EN14525 standard.

This improved range of UPE Universal wide tolerance couplings and flange adaptors can be used on almost any plain-ended rigid pipe material from 40mm to 300mm pipe nominals. This flexibility combined with each fittings ability to accommodate a wide variety of pipe sizes makes the UPE Universal fitting a versatile and economical product to use.

## Improved UPE Universal Fittings



#### How the Universal Gasket Works

The unique, patented\* gasket design provides a highly efficient seal with minimal internal resistance during gasket compression. The gasket compression is illustrated to the right.

When the bolts are tightened the back face of the gasket is held by the taper on the inner face of the end ring. As the bolts are tightened further the slot in the gasket will allow compression with minimal loading. This action enables the gasket to compress radially, providing a strong self centring characteristic. Once the gasket contacts the pipe wall its sealing area progressively increases until the full sealing potential of the gasket and required loading is obtained. Due to the efficient nature of the gasket's compression the product tightening torque reduces significantly from the existing 61 - 68 Nm to 35 - 40 Nm.

In addition to this the bolt travel required to achieve a fully effective seal has been reduced by approximately 30%

#### Technical help

For further technical data, product specifications and general information please contact our Customer Service or Technical Departments at the telephone number shown below.

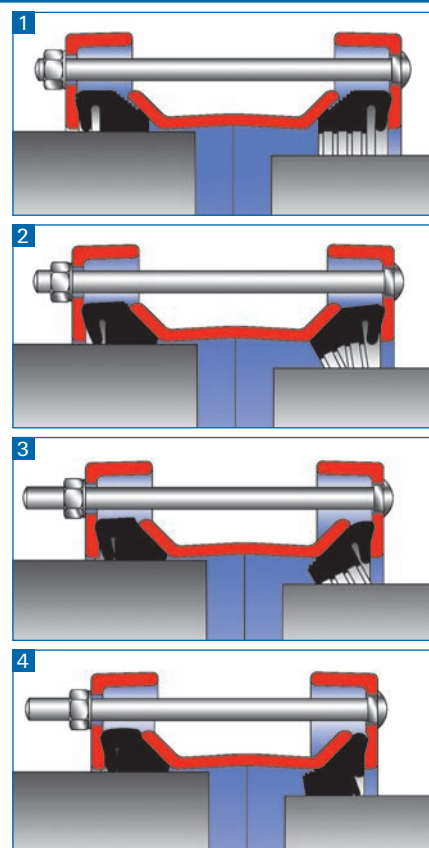

\*Patent pending  
All materials used with the UPE Universal fitting that come into contact with potable water are WRAS listed

## Flange Adaptors - Range, Weights and Dimensions - Items shown in bold available from May 2006

DN	Tolerance Range	Part Number		Weight kg	Hex Bolt (mm) Steel 6.8	Dimensions (mm)		
		Black (NBR)	Blue (EPDM)			Length	Ø	Setting Gap
40	44/57	U6248	U6222	TBA	TBA	TBA	TBA	TBA
<b>50</b>	<b>55/70</b>	U6249	<b>U6206</b>	<b>3.00</b>	<b>M12 x 140</b>	<b>151</b>	<b>176</b>	<b>19mm</b>
<b>65</b>	<b>68/86</b>	U6250	<b>U6207</b>	<b>4.00</b>	<b>M12 x 140</b>	<b>151</b>	<b>191</b>	<b>19mm</b>
<b>80</b>	<b>84/106</b>	U6251	<b>U6208</b>	<b>4.70</b>	<b>M12 x 140</b>	<b>151</b>	<b>211</b>	<b>19mm</b>
<b>100</b>	<b>106/130</b>	U6252	<b>U6209</b>	<b>5.70</b>	<b>M12 x 140</b>	<b>151</b>	<b>241</b>	<b>19mm</b>
125	125/148	U6253	U6223	TBA	TBA	TBA	TBA	TBA
125	140/161	U6254	U6224	TBA	TBA	TBA	TBA	TBA
<b>150</b>	<b>159/184</b>	U6255	<b>U6210</b>	<b>7.50</b>	<b>M12 x 140</b>	<b>153</b>	<b>279</b>	<b>19mm</b>
175	180/205	U6256	U6225	TBA	TBA	TBA	TBA	TBA
200	200/227	U6257	U6226	TBA	TBA	TBA	TBA	TBA
<b>200</b>	<b>218/245</b>	U6258	<b>U6211</b>	<b>13.10</b>	<b>M12 x 200</b>	<b>214</b>	<b>335</b>	<b>19mm</b>
225	243/271	U6259	U6227	TBA	TBA	TBA	TBA	TBA
250	270/297	U6260	U6228	TBA	TBA	TBA	TBA	TBA
250	292/318	U6261	U6229	TBA	TBA	TBA	TBA	TBA
300	311/336	U6262	U6230	TBA	TBA	TBA	TBA	TBA
300	334/361	U6263	U6231	TBA	TBA	TBA	TBA	TBA

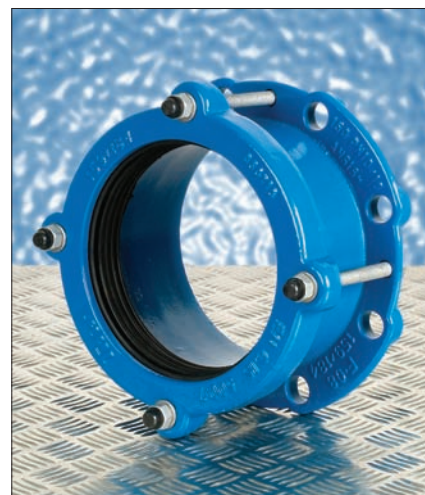

## Flange Adaptors - Flange Drillings - Items shown in bold available from May 2006

DN	Tolerance Range	Part Number		EN 1092-2 (BS4504) ISO7005-1 1992	BS10 Table D/E	AS4087:2004	ANSI B16
		Black (NBR)	Blue (EPDM)				
40	44/57	U6248	U6222	DN40/50 x PN10/16/25	-	DN50 x PN14	-
<b>50</b>	<b>55/70</b>	U6249	<b>U6206</b>	<b>DN 50/65 x PN10/16/25/40</b>	-	<b>DN65 x PN14/16</b>	<b>Class 125/150 (2.5")</b>
<b>65</b>	<b>68/86</b>	U6250	<b>U6207</b>	<b>DN65/80 x PN10/16/25/40</b>	-	<b>DN80 x PN14/16</b>	<b>Class 125/150 (2.5"/3")</b>
<b>80</b>	<b>84/106</b>	U6251	<b>U6208</b>	<b>DN80/100 x PN10/16/25/40</b>	<b>3.5"</b>	<b>DN100 PN14/16</b>	<b>Class 125/150 (3.5")</b>
<b>100</b>	<b>106/130</b>	U6252	<b>U6209</b>	<b>DN100/125 x PN10/16</b>	<b>4"</b>	<b>DN100 PN14/16</b>	<b>Class 125/150 (3.5"/4")</b>
125	125/148	U6253	U6223	DN125/150 x PN10/16	5" & 6"	DN150 x PN14/16	Class 125, 150, 250, 300 (5"/6")
125	140/161	U6254	U6224	DN125/150 x PN10/16	5" & 6"	DN150 x PN14/16	Class 125, 150, 250, 300 (5"/6")
<b>150</b>	<b>159/184</b>	U6255	<b>U6210</b>	<b>DN150 x PN10/16</b>	-	-	<b>Class 125/150 (6")</b>
175	180/205	U6256	U6225	DN200 x PN10/16	-	-	Class 125/150 (8")
200	200/227	U6257	U6226	DN200 x PN10/16	-	-	Class 125/150 (8")
<b>200</b>	<b>218/245</b>	U6258	<b>U6211</b>	<b>DN200 x PN10/16</b>	-	-	<b>Class 125/150 (8")</b>
225	243/271	U6259	U6227	DN250 x PN10/16	-	-	Class 125/150 (10")
250	270/297	U6260	U6228	DN250 x PN10/16	-	-	Class 125/150 (10")
250	292/318	U6261	U6229	DN250 x PN10/16	-	-	Class 125/150 (10")
300	311/336	U6262	U6230	DN300 x PN10/16	12"	DN300 x PN16	Class 125/150 (12")
300	334/361	U6263	U6231	DN300 x PN10/16	12"	DN300 x PN16	Class 125/150 (12")

## Couplings - Range, Weights and Dimensions - Items shown in bold available from May 2006

DN	Tolerance Range	Part Number		Weight kg	CSq Bolt (mm) Steel 6.8	Dimensions (mm)		
		Black (NBR)	Blue (EPDM)			Length	Ø	Setting Gap
40	44/57	U6232	U6212	TBA	TBA	TBA	TBA	TBA
<b>50</b>	<b>55/70</b>	U6233	<b>U6200</b>	<b>2.90</b>	<b>M12 x 170</b>	<b>177</b>	<b>159</b>	<b>19mm</b>
<b>65</b>	<b>68/86</b>	U6234	<b>U6201</b>	<b>3.90</b>	<b>M12 x 170</b>	<b>177</b>	<b>171</b>	<b>19mm</b>
<b>80</b>	<b>84/106</b>	U6235	<b>U6202</b>	<b>4.80</b>	<b>M12 x 170</b>	<b>177</b>	<b>197</b>	<b>19mm</b>
<b>100</b>	<b>106/130</b>	U6236	<b>U6203</b>	<b>5.90</b>	<b>M12 x 170</b>	<b>177</b>	<b>225</b>	<b>19mm</b>
125	125/148	U6237	U6213	TBA	TBA	TBA	TBA	TBA
125	140/161	U6238	U6214	TBA	TBA	TBA	TBA	TBA
<b>150</b>	<b>159/184</b>	U6239	<b>U6204</b>	<b>8.30</b>	<b>M12 x 190</b>	<b>197</b>	<b>281</b>	<b>19mm</b>
175	180/205	U6240	U6215	TBA	TBA	TBA	TBA	TBA
200	200/227	U6241	U6216	TBA	TBA	TBA	TBA	TBA
<b>200</b>	<b>218/245</b>	U6242	<b>U6205</b>	<b>11.00</b>	<b>M12 x 220</b>	<b>227</b>	<b>345</b>	<b>19mm</b>
225	243/271	U6243	U6217	TBA	TBA	TBA	TBA	TBA
250	270/297	U6244	U6218	TBA	TBA	TBA	TBA	TBA
250	292/318	U6245	U6219	TBA	TBA	TBA	TBA	TBA
300	311/336	U6246	U6220	TBA	TBA	TBA	TBA	TBA
300	334/361	U6247	U6221	TBA	TBA	TBA	TBA	TBA



## Tyco Waterworks

Edison Road

Hams Hall Distribution Park

Coleshill, Birmingham

B46 1AB United Kingdom

Telephone: +44 (0)1675 437 900

Facsimile: +44 (0)1675 437 909

e-mail: [wwinfo@tyco-valves.com](mailto:wwinfo@tyco-valves.com)

web: [www.tycowaterworks.com](http://www.tycowaterworks.com)

## Product Introduction

This new range of Universal fittings will be fully introduced by the end of 2006. Initial supply will be the popular sizes highlighted above in bold and will be available from May 2006 in Blue EPDM format. All other sizes will become available during autumn 2006 together with additional options of stainless steel bolting and a black NBR product for use with gas. The range will be further enhanced with stepped couplings and end caps during early 2007.

The existing range of UPE universal fittings will continue to be available until the end of 2006.

We reserve the right to change the design and specification without notice.

© Tyco 2007 .pdf (06/07) TUPE/101.3